

# **EUROFEL-Report-2007-DS3-083**

## *EUROPEAN FEL Design Study*



Deliverable N°: D 3.7  
Deliverable Title: Jitter monitoring with undulator radiation  
Task: DS-3  
Authors: Andrea Doria et al.  
Contract N°: 011935

**Project funded by the European Community  
under the “Structuring the European Research Area” Specific Programme  
Research Infrastructures action**

# JITTER MONITORING WITH UNDULATOR RADIATION

The ENEA participation in the DS3 Work-package of the EUROFEL Project concerns the synchronism and evaluation of the time jitter between the electron beam and a Visible-UV light pulse in the seeding experiment of the SPARC source.

SPARC is a Free Electron Laser (FEL) [1] source based on an S-band Linac with an energy ranging from 150-180 MeV. The e-gun is a 7 MeV RF device using a Copper photocathode powered by a Ti:Sa laser. The SPARC source will operate both in the SASE (Self Amplified Spontaneous Emission) and in the Seeded regime; the designed operating spectral range extends from about 500 nm for the fundamental harmonic down to about 100 nm for the fifth harmonic. In order to avoid the chaotic generation of the light signal, typical of the SASE mechanism, a Seeding experiment has been designed [2] using the non-linear generation of Ti:Sa harmonics on a Gas-Jet. The radiation pulse generated is injected into the SPARC transport line in order to be over-imposed to the electron bunch right at the entrance of the first undulator section; this synchronisation is ensured by a properly designed delay line described in the ENEA-Deliverable 1 [3].

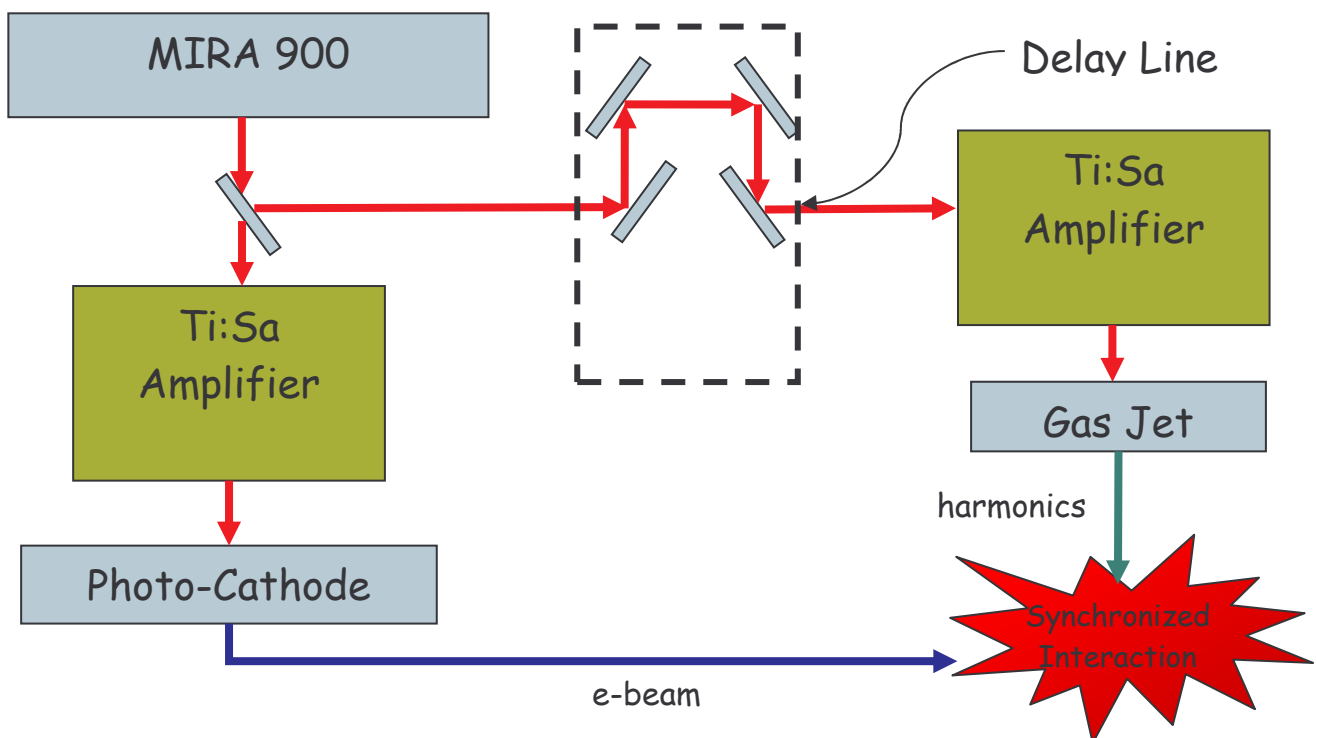

Fig.1: General scheme of the seeding mechanism including the Laser system with the two amplifying chain.

Before the final installation of the delay line in the SPARC-Hall some characterising tests have been performed. The delay-line is based on a MICOS belt-driven stage with 1600 mm travel length. Movement is powered by a stepper motor (200 steps/turn) and the position is guaranteed by an optical linear encoder, with 1600 mm of length and 1  $\mu\text{m}$  of resolution, operating in closed-loop. Power supply and control is based on a two-axes PCI board.



Fig. 2 The Delay Line tested at the ENEA Laboratory

Experiments on the planarity of the system and on the straightness of the rail movement have been performed in the ENEA laboratories using an HeNe Laser properly aligned with the linear stage; the laser spot position on an Hamamatsu sensor screen gives an analog voltage signal that has been monitored during the stage travel. A LabView based acquisition software has been developed to collect transverse position data from the Hamamatsu sensor and stage position data from the MICOS optical encoder. A typical result is reported in the Fig.3.

Observing the data for the whole length the maximum deviation in the horizontal direction is of about 180  $\mu\text{m}$ , while in the vertical is limited to about 130  $\mu\text{m}$ . Limiting the analysis to about 500 mm around the central part of the linear stage the stability appears to be higher, the maximum deviation is, in fact, now 60  $\mu\text{m}$  in the horizontal and 20  $\mu\text{m}$  in the vertical directions. The analysis of many different scans gives a very high reproducibility of the movement, giving a maximum difference among them of about 20  $\mu\text{m}$  both for the horizontal and vertical directions; the standard deviation from the mean value is about 4  $\mu\text{m}$  again for both the directions.

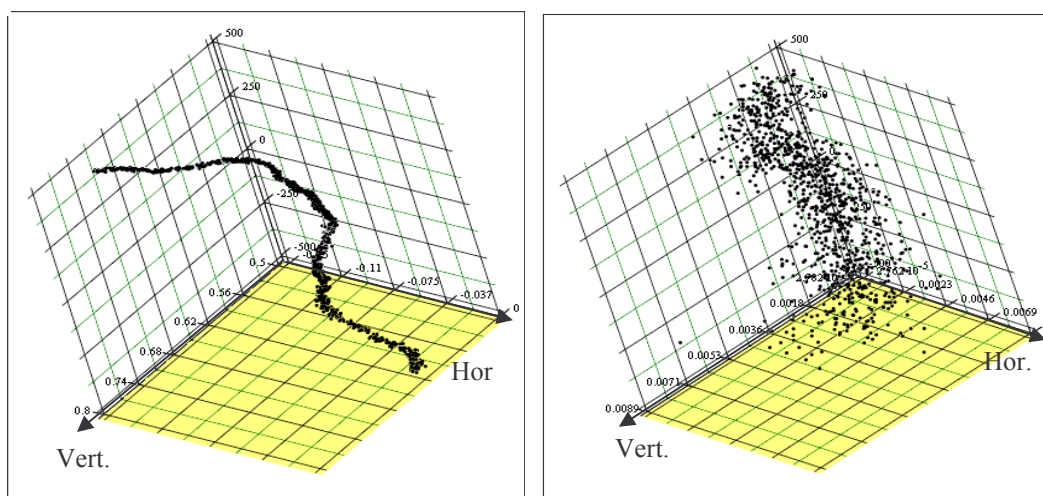

$$(D^{(0)}, D^{(1)}, D^{(2)})$$

$$(DEV^{(0)}, DEV^{(1)}, B^{(2)})$$

Fig.3:

The Delay Line is now installed in the Laser Clean Room into the SPARC-Hall and controls the synchronism delaying the oscillator seed entrance into the Coherent Legend amplifier. The Mira

oscillator is located in a second Clean Room at the injector level, while the amplifier clean room is positioned at the level of the transfer line between the linac and the undulators. The transport of the radiation is done by means of two periscopes translating the optical axis at about 15 cm from the ground. The optical path between the two laser is  $\approx 15\text{m}$ .

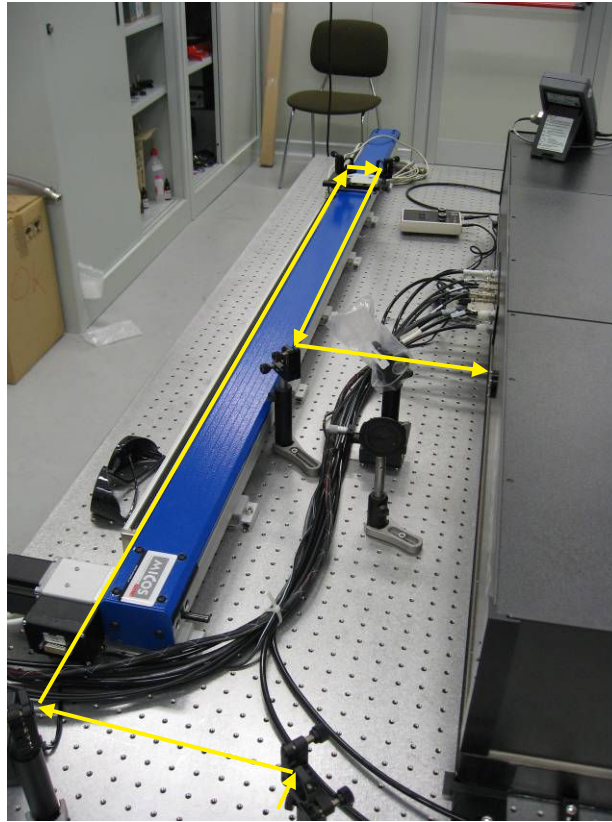

Fig.4: On the left the delay line for the synchronization with the e-beam is visible

The synchronism is then ensured by the delay line, but observing Fig.1 we may understand that there are many possible sources contributing to the jitter that can arise from a system like this. For instance different noise mechanisms from the two laser amplifiers, thermal contributes from the photoemission process, pressure fluctuation in the gas jet may change the radiation propagation path, etc. Thus the necessity of analysing such a jitter becomes important for a successful performing of the seeding experiment.

The time scale of the radiation pulse in the SPARC SASE FEL process is extremely small, of the order of 3 ps r.m.s, and further smaller, few tens of femtoseconds, for the seeding experiment. It is thus impossible to measure the temporal pulse profile with conventional detectors which usually have time responsivity not much better than 1 ns. There are, however, some well known techniques with which it is possible to measure the time profile of short radiation pulses: the first method consists in using very fast electro-optical systems like Streak Camera. The second methods consist in using all optical techniques.

The first method is easier to apply, but it requires the use of a sophisticated and expensive instrumentation, moreover the best temporal resolution achieved in single shot is of the order of 1 ps. The second method is cheaper, but complex by the experimental point of view and requires information on the shape of the pulse. The advantage is the achievable resolution that can be as high as one femtosecond. Let us analyse the two techniques in detail.

The use of a streak camera has been considered because in the ENEA FEL laboratory a camera has been recently refurbished by Hamamatsu within the EUROFEL project. The streak tube is the original one and it has only been tested by the company indicating resolutions very close to 1 ps. The new imaging unit is a CCD camera with optics down to 200 nm and a new software for the

analysis of the images dispersed in time. Spontaneous emission measurements can be performed with this tool within the first phase of the SPARC project, for which the electron bunch length is of about 10 ps. Similarly Coherent Transition Radiation (CTR) or Cerenkov radiation can be measured for the evaluation of the electron beam profile. Together with these measurements the streak camera can be used for a statistical analysis of the time jitter between the electron beam and the gas-harmonic generated radiation in the seeding experiment in SPARC. The dynamical amplification process requires the necessity of synchronism between the seed and the electron bunch; this synchronisation could be problematic if the time jitter, related to the electron beam generation thread (Ti:Sa laser -> photo-cathode -> electron extraction -> acceleration) and to harmonic generation process (Ti:Sa laser -> gas jet), is longer than their time overlapping.

The measurement of the time jitter becomes complicated by the fact that the streak camera cannot operate in the repetitive regime because of the time structure of the SPARC source, the measurement must be performed in a single shot regime. In this regime the ENEA streak camera has an intrinsic trigger jitter of about 13 ps. To overcome these problems that limit the possibility of the single pulse jitter time evaluation, an experimental configuration has been proposed and it is reported in Fig.5.

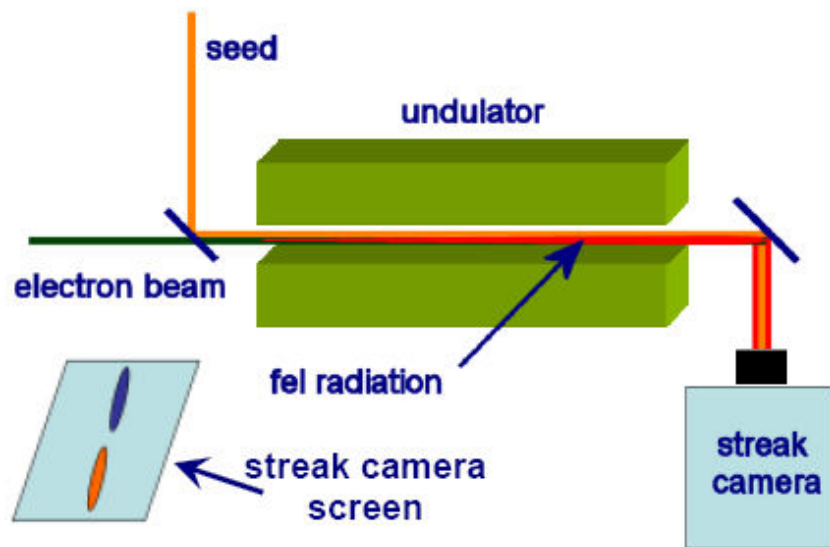

Fig.5 Experimental layout of the jitter measurement in the SPARC seeding experiment

The seed, generated in the Gas-Jet, is injected into a proper chamber that hosts a 45° mirror and an e-beam chicane that allows the electrons to freely propagate and overlap the seed pulse. A picture of the chamber is reported in Fig.6. The chicane deflects the e-beam from the Linac axis and a periscope allows the control of the harmonic generated optical beam position at the undulator entrance. The layout of the transfer line has been modified in order allow the electron beam to perform the small “orbit chicane” and avoid interaction with the photon beam injected at the periscope, while they need to be superimposed at the undulator entrance. The required orbit bump is from 5 to 10 mm at the periscope location. This element is installed in the middle of the SPARC transfer line. The vertical periscope is constituted by two chambers containing piezo-controlled mirror holders allowing the alignment of the radiation.

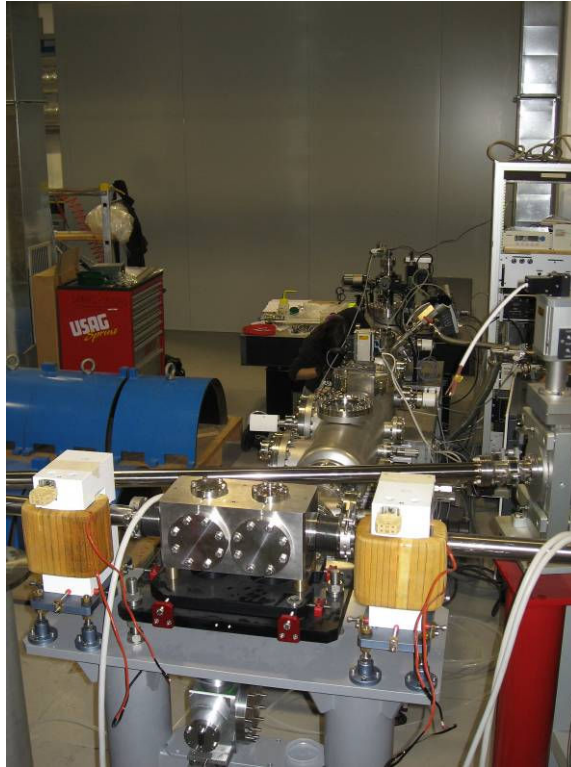

Fig.5: Injection chicane and periscope chamber

The two optical pulses under analysis are the spontaneous emission generated by the electrons and the seed itself. The two optical pulses can be separated in time by a proper amount in order to be captured by the screen of the Streak Camera, but still maintaining an appreciable distance. This can be done with the previously described delay line on the seed trajectory. Due to the limited dynamic of the camera, the power level will be controlled attenuating the stronger of the two pulses. The streak camera is then triggered by the first of the two optical pulses arriving on the tube that acts as a reference. The presence of the intrinsic 13 ps jitter of the optical trigger may shift the two images on the screen from one shot to the following by a quantity comparable to the 13 ps, but the time separation of the two signals remains constant except for the quantity that can be ascribed to the relative jitter that is the parameter that we want to estimate; this happens because the intrinsic jitter applies to both the pulses.

With the new software of the camera it is possible to analyse the data by measuring the distance of the maxima of the two spots, and then making a statistics after many shots. It is worth to stress that due to the limited dynamics of the Streak Camera it will be important to maintain the amplitude of the two shots comparable, by means of proper attenuation devices.

These measurements will be part of the first tests in program for the seeding experiment at SPARC.

## REFERENCES

- [1] SPARC Collaboration, Nucl. Instr. & Meth. A507 (2003) 345-349, see also <http://www.sparc.it>
- [2] L. Poletto et al., EUROFEL-Report-2005-DS4-008 1st Technical Design Report for the Seeding@SPARC experiment.
- [3] ENEA Ds3 Deliverable 1: "Design of the Optical Delay Line".