

Status of the laser based synchronization system at FLASH

**F. Löhl, F. Ludwig, H. Schlarb, S. Simrock, A. Winter (DESY)
J. Kim, F. X. Kaertner (MIT)**

7/25/2006

Holger Schlarb, DESY

Overview of FLASH linac

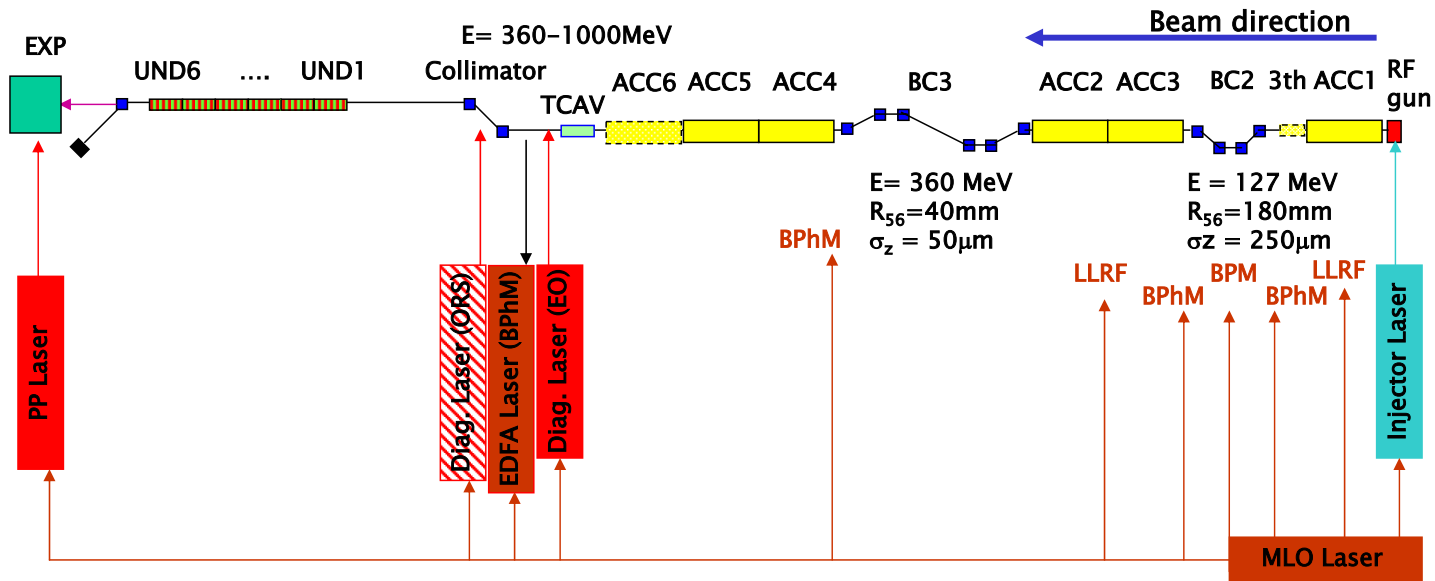

- Laser based system is upgrade of existing RF synchronization
- Serves as prototype for XFEL

7/25/2006

Holger Schlarb, DESY

Source of timing jitter

- Caused by RF acceleration prior BC-

Timing jitter Behind BC	Gradient	Phase	Incoming Timing jitter
↓	↓	↓	↓
$\Sigma_t^2 \approx \left(\frac{R_{56} \sigma_A}{c_0 A} \right)^2 + \left(\frac{C-1}{C} \right)^2 \left(\frac{\sigma_\phi}{c_0 k_{rf}} \right)^2 + \left(\frac{1}{C} \right)^2 \Sigma_{i,t}^2$			
	6.0 ps/%	2 ps/deg	0.05 ps/ps

C compression factor (20)

R₅₆ ~ 180 mm

k_{rf}: wavenumber RF acceleration (27.2/m)

↑
Only if not
corrected

Vector sum regulation of 8 cavities => 1 deg == 1.8% (statistic 8 cav. helps)

But! Phase changes can be correlated due to local oscillator changes

Arrival time sensitivity measurements

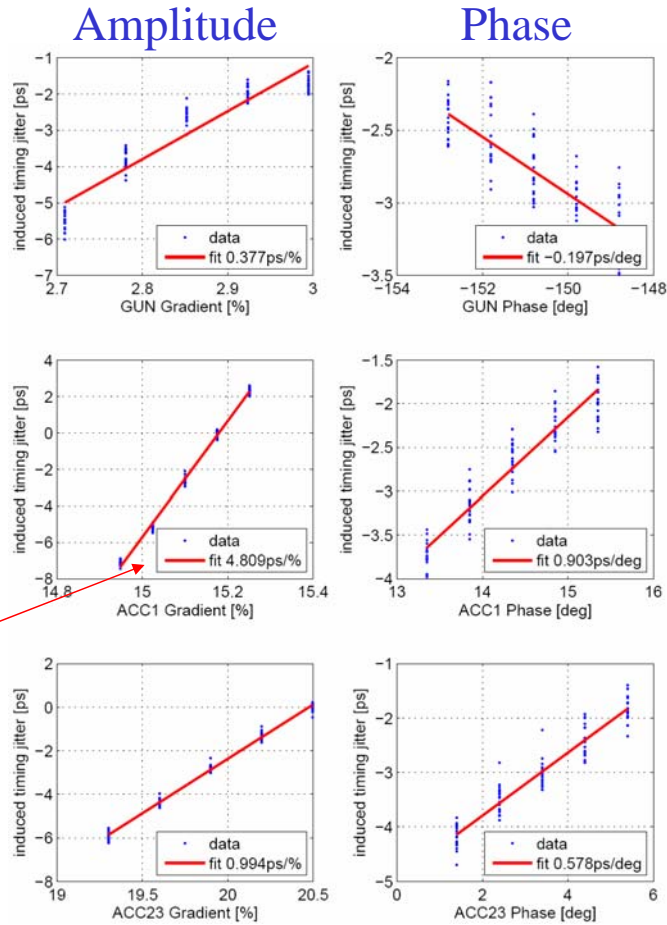

Gun

Acc1

Acc23

Acc45 no effect

Most critical
at FLASH
4.8 ps/%

7/25/2006

Arrival time measurements

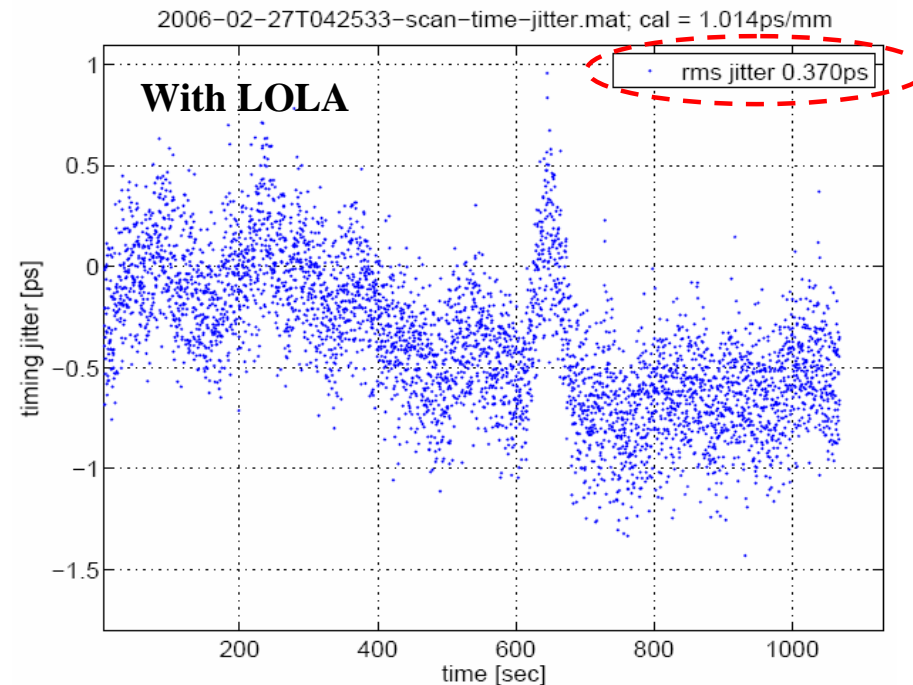

From BPM system easily sub 10fs resolution can be obtained

But! 1) RF cavity phase not known with sufficient precision

2) LO for phase measurement critical device!

7/25/2006

Holger Schlarb, DESY

Arrival time measurements

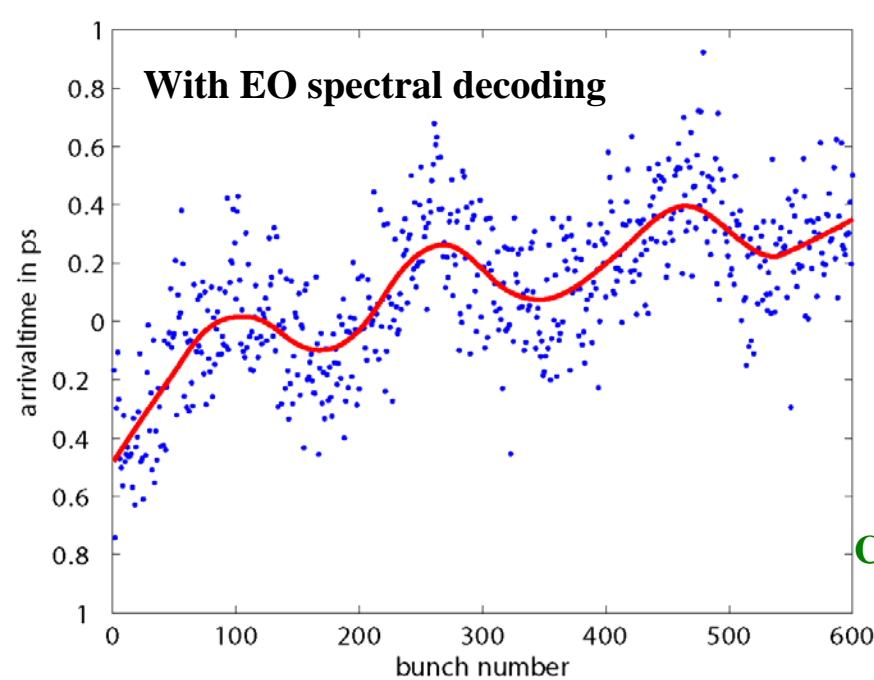

Courtesy B. Steffen

TiSa laser system is much better synchronized to reference RF (<30fs)

Timing jitter 300 sec ~ 270 fs (rms)

If correlation removed ~ 200 fs (rms)

7/25/2006

Holger Schlarb, DESY

Some conclusions:

- synchronization of the electron beam is **dominated** by **RF stability** of sections upstream of first bunch compressors (next generation LLRF controls + DCW)

⇒ **EUROFEL Project on Down-converter + connection to synchronization laser F. Ludwig**

- **beam based feedbacks** to stabilize arrival time & peak current requires to measure energy & incoming arrival time

⇒ **EUROFEL Project on compact beam phase monitor (F. Löhl & Triste)**

- fs stability requires **$\sim 10^{-6}$** amplitude and **0.0001°** phase stability

⇒ **this is hopeless !**

- lasers can be locked to reference with smaller timing jitter (< 10 fs feasible)
- remaining timing jitter need to be measured with high **accuracy** to timing reference system (e.g. for post-ordering, FB etc.)

How can we achieve better synchronization?

Attosecond synchronization!

- outlook & upgrade -

- always based on electron beam manipulation by lasers

Requirements:

1. Electron beam is synchronized to laser $< \sigma_t \sim 30\text{-}60\text{ fs}$
2. Manipulation laser to exp. laser on femtosecond level

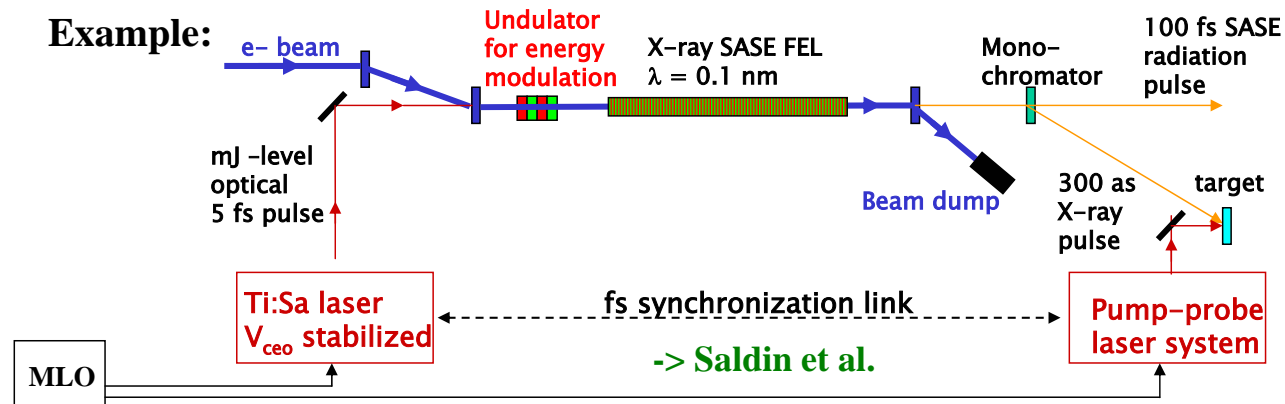

Optical clocks for lasers: synchronized to 100as level within macro pulse (1ms)
Avoids problems with **vibration and diffuse ground motion** ($< 1\text{kHz}$, $30\text{ns}=100\text{as}$)
Fiber link operates at small unity gain frequency (10Hz) for resynchronization

7/25/2006

Holger Schlarb, DESY

Layout of laser based synchronization

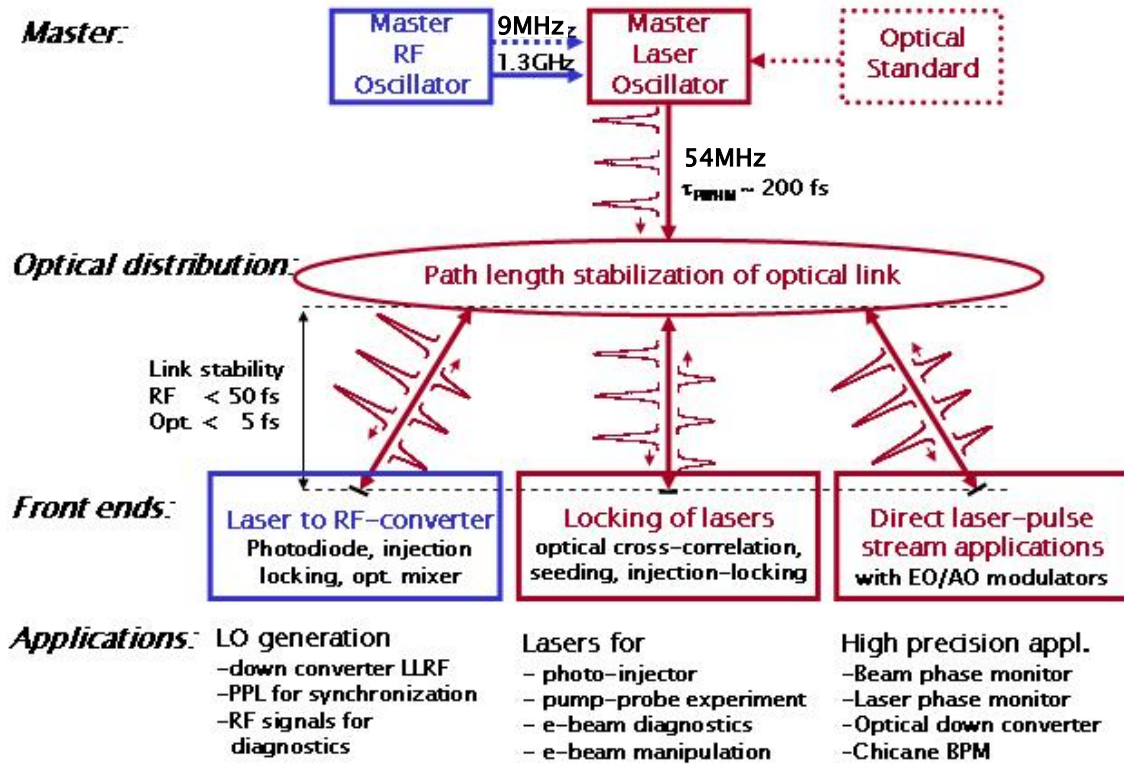

Synchronization laser

Dispersion managed soliton fiber-laser with artificial saturable absorber

- Fiber stretcher for passive mode locking to RF generator
- Gain medium Erbium, 1550 nm wavelength
- High output power up to ~ 1 nJ (50 mW average)
- Pulse duration ~ 100 fs FWHM
- Repetition rate ~ 54 MHz
- Mode lock based on artificial absorber

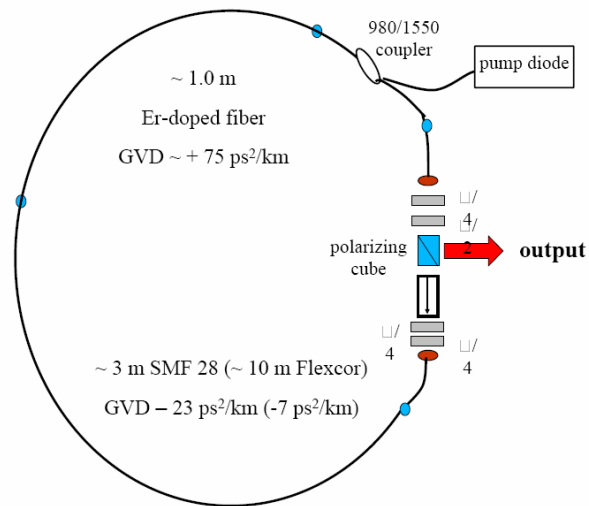

www.bilkent.edu.tr/~ilday

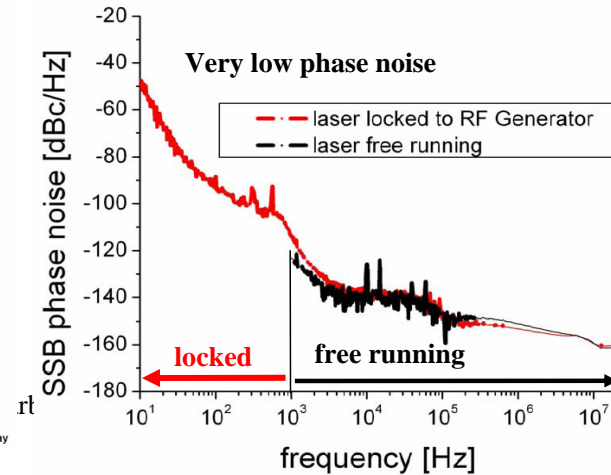
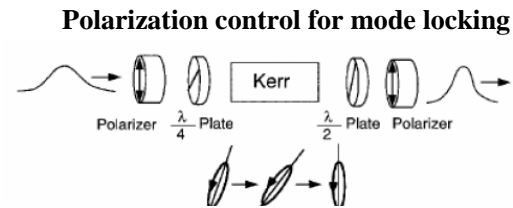

Status of Master Laser

- three fiber lasers build so-far
Experience: mode-lock usually no problem, but RF lock not stable enough
can be cured by improved piezo driver module
temperature stabilization
- concept of redundant systems (compatible outputs ????)
- PPL for phase lock test with digital controller (9/1300MHz)

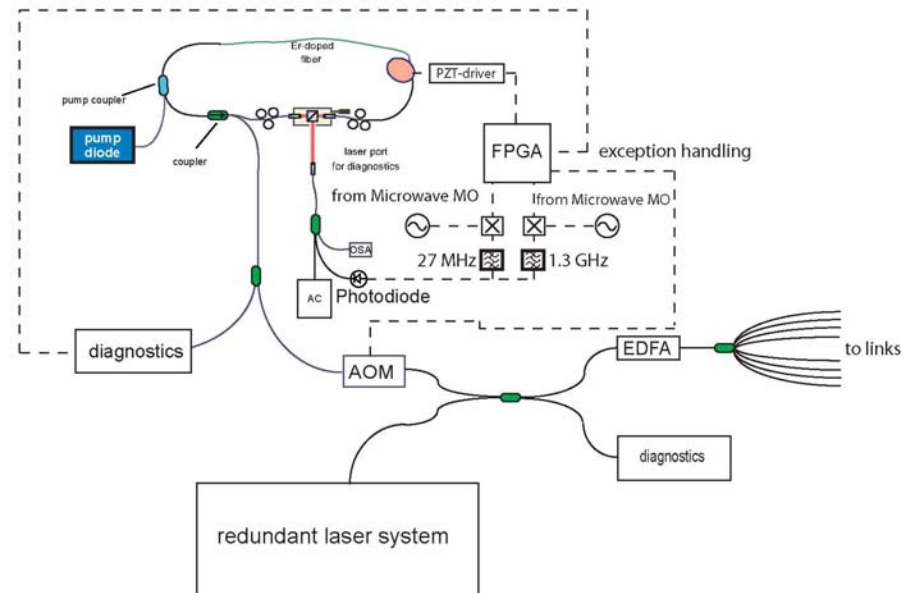

7/25/2006

Status of Master Laser

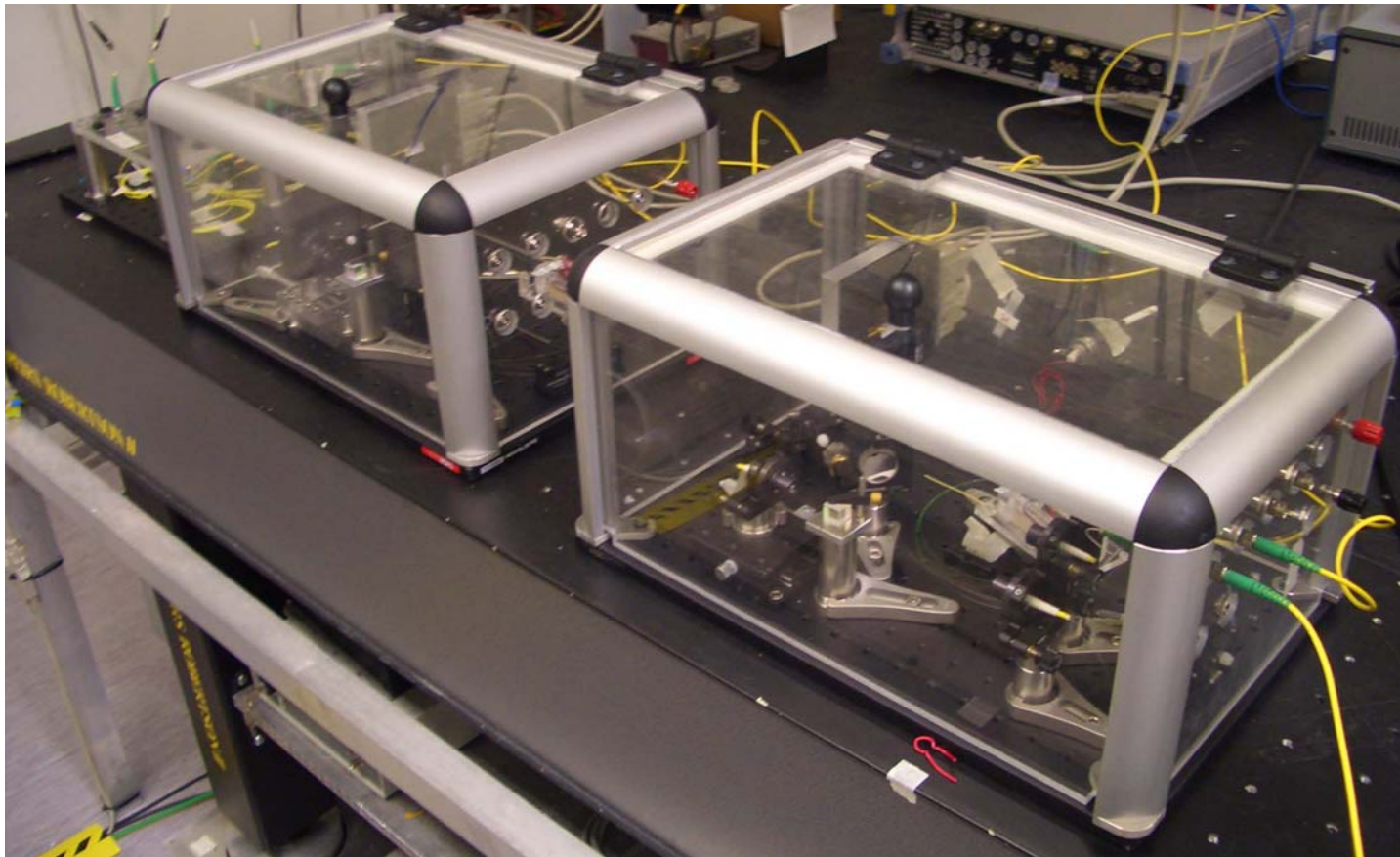

Laser to RF conversion

Mode locked laser pulse train in frequency domain

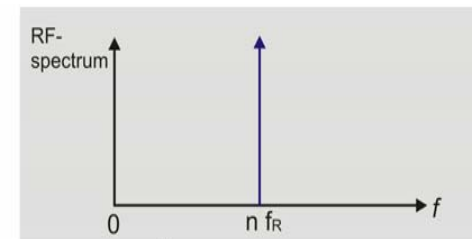
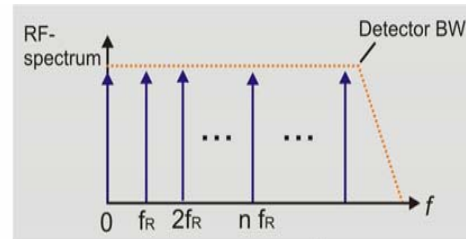

1) Direct conversion:

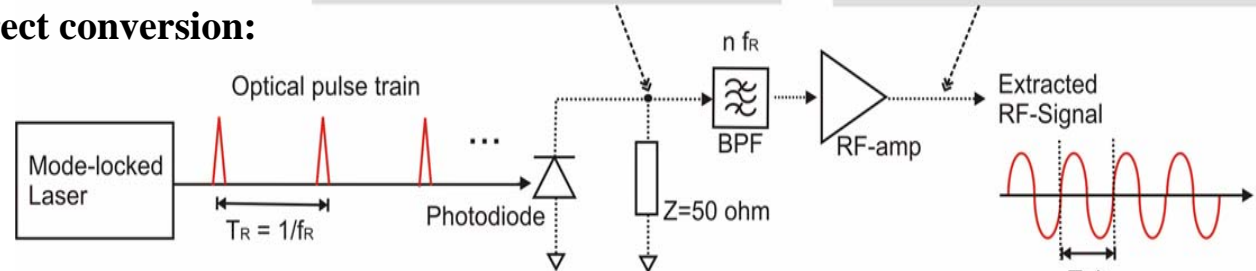

- **AM to PM conversion requires accurate stabilization of laser power (photo-detector 1 ps/mW @ 10mW -> dP/P < 10⁻³ for 1 fs)**
- **Drifts may critical to control since PD and Amplifier are out of loop**
- **Thermal noise limitation of PD due to limited output power (~10fs)**

Laser to RF conversion

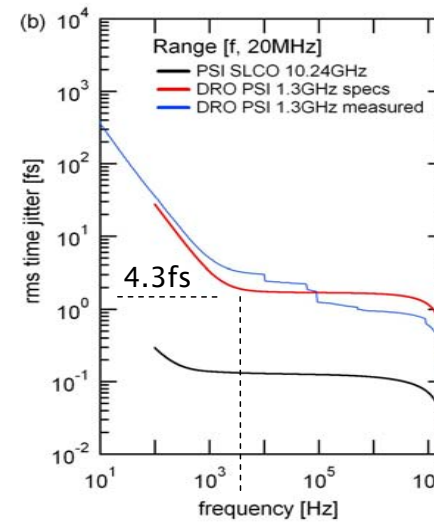
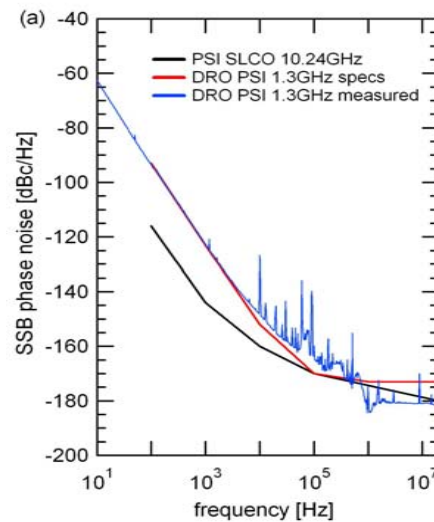
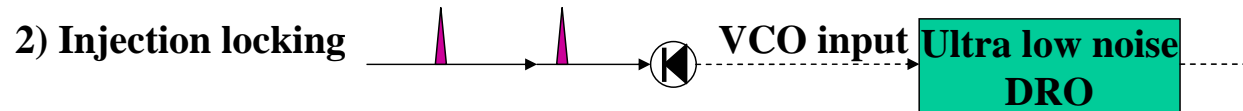

- Still rely on phase detection by photodiode (drift?, ampl. Stab. required)
- + Full PD output used
- + Thermal noise limitation at high offset frequencies given by DRO

7/25/2006

Holger Scharb, DESY

Laser to RF conversion

3) Balanced optical-RF phase detector

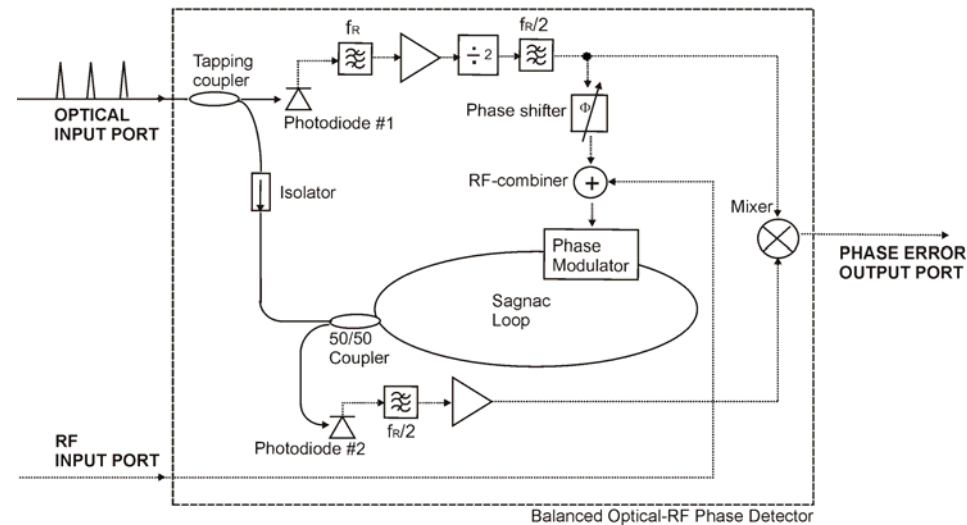

- + Does not rely on phase detection by photodetectors (EOM are used)
- + to first order gain and offset drifts are compensated
- More complex setup

Scheme of L2RF converters

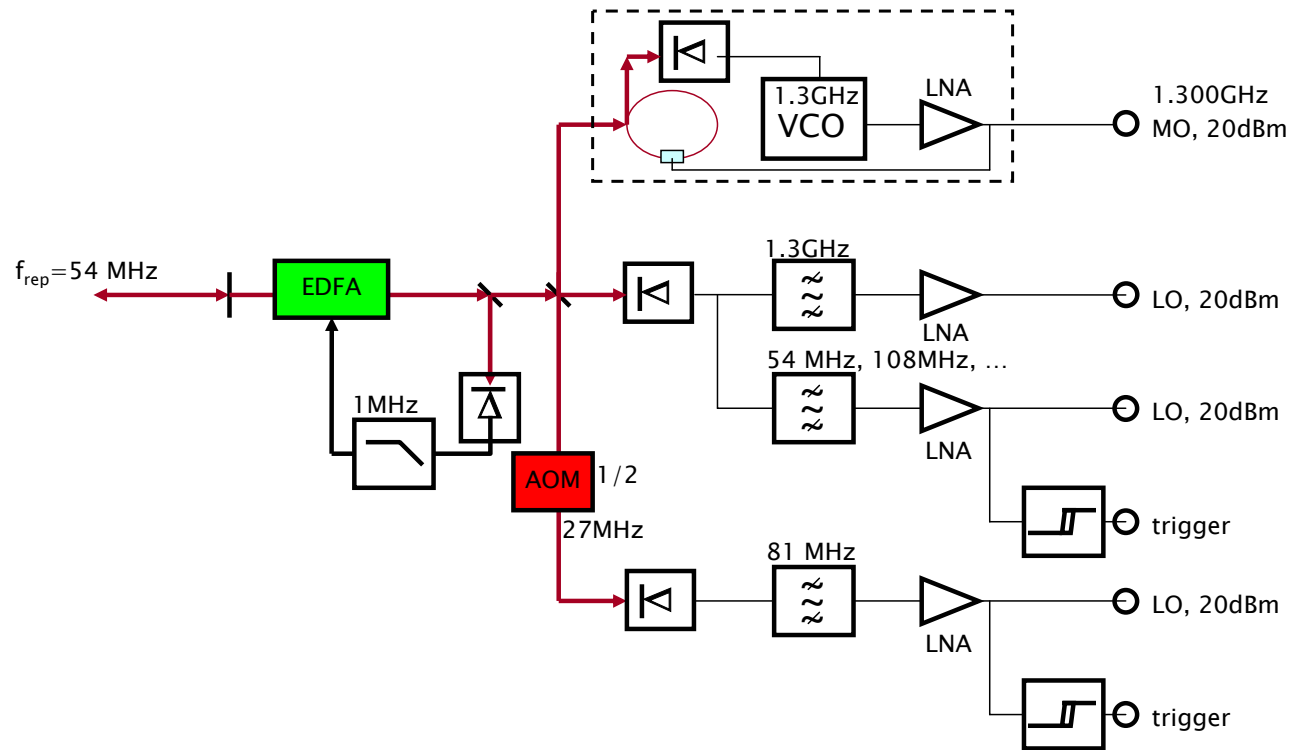

7/25/2006

Holger Scharb, DESY

Front end system & near term projects

- **beam phase monitor**: proof-of-principle very successful
first problems found ... F. Löhler
- Start of **laser seeding** CPA2001 (Clark) for optical replica
- Laser link stabilization is focus for near future
 - limitation of RF detections scheme (thermal drift of PDs)
 - dispersion compensated links
 - two photo detection optical cross-correlator
 - versus bulk SHG system
 - PMD???
- EDFA + SHG for electro-optical sampling
- Optical-cross correlation based lock of laser system

End

7/25/2006

Holger Schlarb, DESY